

Atlas Series Gasoline Pumps

▼ Shown from left to right: **PGM-2408R**



PGM Series

Reservoir Capacity:

1 gallon

Flow at Rated Pressure:

40 in³/min.

Motor Size:

4.2 Ft.lbs

Maximum Operating Pressure:

10,000 psi



Gauges

Minimize the risk of overloading and ensure long, dependable service from your equipment. Refer to the

System Components section for a full range of gauges.

Page: **124**



Hoses

Enerpac offers a complete line of high-quality hydraulic hoses. To ensure the integrity of your system,

specify only genuine Enerpac hydraulic hoses.

Page: **118**

Patented Genesis Technology

- coaxial piston design ensures high performance
- first-stage piston pump for improved efficiency

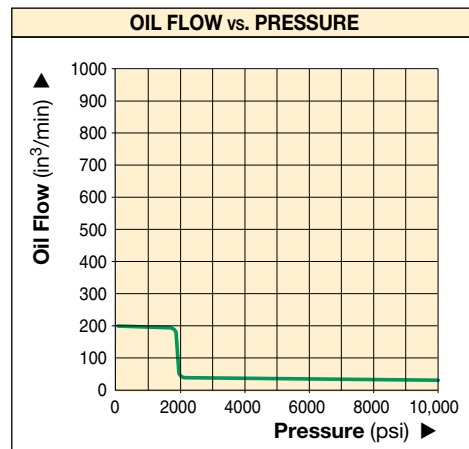
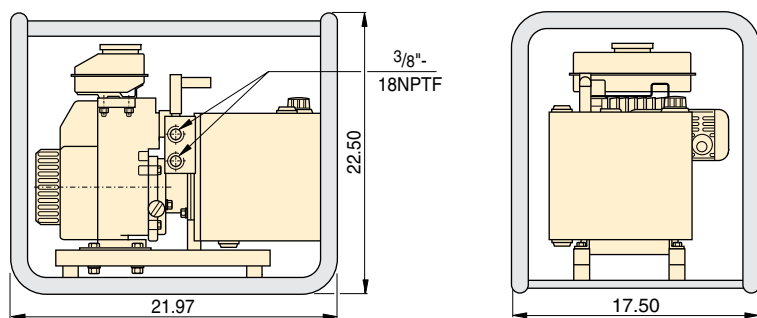

Used with Cylinder	Usable Oil Capacity (gal)	Model Number	Output Flow Rate** (in ³ /min)		Pressure Rating (psi)	Valve Type	Valve Function	Motor Manufacturer	Motor Size (Ft.lbs)	Weight (lbs)
			1 st stage	2 nd stage						
Single-acting	1.0	PGM-2304R*	200	40	10,000	3-way, 3-position	Advance/ Hold/Retract	Honda	4.2 at 3600 rpm	55
	2.0	PGM-2308R*	200	40	10,000	3-way, 3-position				72
Double-acting	1.0	PGM-2404R*	200	40	10,000	4-way, 3-position				55
	2.0	PGM-2408R*	200	40	10,000	4-way, 3-position				72

* Note: PGM-20 Series are available with a carrying handle instead of a Roll Cage. For ordering omit the 'R' from the model number.

** Nominal values—may vary based on motor speed.